

# WINDING ROADS

April 2003



1914  
DODLY BUG

California Inland Region - Porsche Club of America



# Winding Roads

Volume XVIII No. 3

**Editor:**

David Witteried witteried@ccis.com  
9900 Susan Avenue  
California City, CA 93505  
760-373-1413

**Writers:**

David Witteried Gregory Reed  
Mark Charus Paul Turner  
Rich Bessette Rich Paré

**Photographers & Artwork:**

David Witteried Bev Griffin-Frohm  
John Crnkovich

**Advertising:**

David Witteried witteried@ccis.com  
760-373-1413

**Mailing:**

David Witteried witteried@ccis.com

**Printing:**

Four Star Printing fourstar@sbcglobal.net  
661.274.1896

**Proofreading:**

Janice Witteried

**On the Covers:**

Front: A 1914 Dudley Bug from the Petersen automobile collection. The economy car of 1914! One passenger only.

Back: The Porsche hood crest on Bret Luedke's 993. Photo and artwork by David Witteried.

## C O N T E N T S

**Inside this issue**



Things that go Bump...  
(page 3)



Petersen Automotive Museum  
Tour (page 4)



Gymkhana Precision Driving  
Event (page 4)



**Features**

Things that go Bump..... 3  
Petersen Automotive Museum  
Tour..... 4  
How Much per Gallon!..... 7

**Event Fliers**

Cinco De Mayo Concours &  
Autocross (SAR)..... 3  
California Inland Gymkhana Pre-  
cision Driving Event..... 4  
Grand Prix Region Concours  
(GPX)..... 5  
James Dean Memorial Auto-  
cross for Charity (GER)..... 6  
Porsches Wild III (LVR)..... 7  
White Gloves Concours (OCR) 8  
California Inland Gymkhana Pre-  
cision Driving Event..... back

**Departments**

Calendar ..... 1  
Board Of Directors ..... 1  
Committees ..... 1  
Air & Water ..... 2  
From the Zone Rep..... 2  
Watercooled Thoughts ..... 3  
From the Editor's Bench..... 5  
Membership Report..... 6  
Region Secretary Report ..... 7

The Winding Roads is the official publication of the Porsche Club of America California Inland Region and is published monthly. \$14 of each member's annual dues is for subscription to the newsletter. Copies are also available by subscription to non-region members at \$25 per year (Continental U.S.) and for \$32 for overseas surface mail. Any statement appearing in the Winding Roads is that of the author, and does not constitute an opinion of the Porsche Club of America, the California Inland Region, its Board of Directors, the Winding Roads editors or its staff. The editorial staff reserves the right to edit all material submitted for publication. © 2003 by the Porsche Club of America, California Inland Region. All rights reserved. Permission is given to charter regions of PCA to reprint articles in their newsletter if credit is given to the author and the Winding Roads. Office of publication: 9900 Susan Avenue, California City CA 93505. POSTMASTER: Address change to PCA-CIR Membership, 2248 Greenhill Street, Roseland CA 93560.

# California Inland Region



Event Calendar — <http://www.pca.org/cai>

See event flyer in this issue 

## April

- 5 Breakfast Meeting - 9:30 @ Greenhouse Cafe, Lancaster
- 12 Gymkhana/Precision Driving Contest, POC - Paul Turner 661.823.9753 
- 16 Board Meeting - 5:30 @ Zuma's restaurant, Rosemond
- 19-20 Porsches Wild - Las Vegas Region (Concours & Autocross)



### Zone 8

- 13 Pomona Swap Meet
- 19 Concours, Las Vegas Region 
- 20 Autocross, Las Vegas Region 
- 26 Rally, Santa Barbara/Cal Central Coast

## May

- 3 Breakfast Meeting - 9:30 @ Greenhouse Cafe, Lan.
- 3 Tortoise Days Car Show and BBQ – California City, POC - Dave Witteried 760.373.1413
- 17 Portuguese Pass Tour — mountain driving at its best! POC - David Witteried 760.373.1413
- 21 Board Meeting - 5:30 @ Zuma's restaurant, Rosemond
- 31 Tribute to Le Mans/Barbecue - Willow Springs Raceway

### Zone 8

- 3 Concours, Southern Arizona Region 
- 4 Autocross, Southern Arizona Region 

- 24 Autocross, Golden Empire Region 
- 25 Concours, Grand Prix Region 

## June

- 7 Breakfast Meeting - 9:30 @ Greenhouse Cafe, Lancaster
- 13-15 Hearst Castle Tour (Double-overnighter) POC – Jennifer Williams
- 18 Board Meeting - 5:30 @ Zuma's restaurant, Rosemond

### Zone 8

- 1 Concours, Orange Coast Region 
- 1 Pomona Swap Meet
- 6-7 Club Race, San Diego Region
- 8 Concours, Los Angeles Region
- 22-28 Porsche Parade in Tampa FL
- 28 Rally, Orange Coast Region

## July

- 5 Breakfast Meeting - 9:30 @ Greenhouse Cafe, Lancaster
- 16 Board Meeting - 5:30 @ Zuma's restaurant, Rosemond
- 19 Mount Whitney Hike and Picnic Tour, POC – Paul Turner 661.823.9753

### Zone 8

- 13 Concours, Riverside Region (new)
- 13 Pomona Swap Meet
- 20 Concours, Central Coast Region
- 26 Autocross, San Diego Region

## Board of Directors:



President:  
Rich Paré



Vice President:  
Paul Turner



Past-President:  
David Witteried

### President—Rich Paré

3460 Granite Court  
Rosamond, CA 93560  
661.256.348 6rmapare@yahoo.com

### Secretary—Mark Charus

3109 Coyote Road  
Palmdale, CA 93550  
661.274.2744 mcharus1@excite.com

### Vice President—Paul Turner

18100 Churchill Street  
Tehachapi, CA 93561  
661.823.9753  
pdtturner20@hotmail.com

### Treasurer—Mary Ann Paré

3460 Granite Court  
Rosamond, CA 93560  
661.256.348 6rmapare@yahoo.com

### Past President—David Witteried

9900 Susan Avenue  
California City, CA 93505  
661.373.1413  
witteried@ccis.com



Secretary:  
Mark Charus



Treasurer:  
Mary Ann Paré



## Committees:

### Newsletter/ Webmaster

David Witteried  
760.373.1413  
witteried@ccis.com



### Autocross

Rich Bessette  
661.256.8493  
richb4@mindspring.com



### Membership

Gregory Reed  
661.256.6144  
gtreed@2si.us



# Air & Water

by Rich Paré — President



Wow, it's time for another issue to be published, time sure flies when you are having fun. We had another good turnout at the monthly breakfast

meeting, our membership is growing and several more member candidates are considering joining the club. They just need a bit more help to choose to join.

I met a Navy pilot yesterday who had just bought a Chalon bodied '73 914. He wasn't sure what he had, he bought it because it looked neat, and it was cheap. It doesn't have an engine or transmission, but that's not a problem. There is so much available out there between the Pomona swap meet, and advertisements in the Pano and local regions ads. He lives in the Santa Barbara Region area, so I hooked him up with the SBR member chairman. My Marine neighbor also hooked me up with another Marine who has a '74 914, I will be approaching him about membership as well. Which brings to mind the fact that as



Tim and Brian O'Hearn with friend Eric Kimble (interested in membership) speak with our region president Rich Paré. Photo by David Witteried.

one on, LAFD folks in one place lined up giving the runners and walkers high-fives and offering encouragement. Yes it was a once in lifetime experience, the key word being ONCE!

PCA members we are all recruiters and should be on the lookout for new member candidates? As I said before, our membership is growing; let's help it grow even more!

On the personal side, many of you knew of my endeavor last weekend, many more of you did not. It turned out to be a beautiful day in Los Angeles for the XVIII L.A. Marathon. Eight hours, fifty-eight minutes and forty-six seconds after starting, I struggled across the finish line, held up by my lovely bride Mary Ann. She went the last mile with me, as I held on to her for support. She quite literally carried me to the finish line! Everything was fine until just after mile 19, and a huge "wall" suddenly appeared in front of me. The last seven miles were extremely slow and long, but eventually I made it. Now, go ahead, ask me...

Will I ever do it again? NOT VERY LIKELY!

It was a wonderful one-time experience, lots of entertainment along the way, LA residents lining the streets cheering every-

one on, LAFD folks in one place lined up giving the runners and walkers high-fives and offering encouragement. Yes it was a once in lifetime experience, the key word being ONCE!

Coming up on April 15th, is our neighboring region's (Golden Empire)

**Ted's Service Center**  
 42500 10th. St. West  
 Building C  
 Lancaster, CA. 93534  
 (661) 942-2422

**Ted C. Tanner**  
 Owner

**German Car Specialists**

annual dinner tour and meeting in Tehachapi at Domingo's Restaurant. This is a great opportunity to meet other people with similar interests and build relationships that will last a long time. More info on this will be forthcoming.

Check out the events calendar for events and happenings in our own region. A lot of time and effort has been expended to create a schedule of events to challenge all of us. Hope to see you soon.

Until next month, keep the shiny side up. ●



# From the Zone Rep

by Mike Mansolino —Zone 8 Representative



NATIONAL NEWS  
At the recent PCA winter meeting, Tom Bobbitt, PCA President, spoke of the importance of having a club that is about

fun, friends, and support for one another. To emphasize support, he read an email from Kellea Garcia (GER) in which she expressed her appreciation for the help and support offered by Donald Bond. Tom was impressed, and

I'm sure Donald was delighted to know his presentation at the January seminar was valuable. Tom also indicated that there were delays in getting a vendor contract for the upgraded executive office software, but a decision will be reached shortly. Tom requested that individuals having an interest in serving at the national level complete a PCA Volunteer form.

PCA is now approaching 54,000 members. 65-percent of new members are joining over the web site. The Quest program (a non-member can receive Pano for 6 months and access on-line classified) is attracting 30-40 subscribers per month. This is a great program to share with prospective Porsche



owners and PCA members.

Tom McKenny, Parade Chair, indicated that the site of the Tampa Parade, Saddlebrook Resort is a first class resort. Some openings still exist. This Parade will host a DE at Sebring, and a tour to the Collier Museum.

Jack Bair, PCNA liaison with PCA and PAG reports that plans are under way to offer a Parts Certificate program similar to the one received last year. Treffen is a Porsche factory tour program designed for PCA members and is an exciting way to experience Porsche up close and personal. It was reported that Treffen would now offer

(Continued on page 8)



# Things that go Bump...

by Janice Witteried

Reprinted from Winding Roads, October 1996.

My husband and I own a 1976 911S Targa. I don't usually drive it on the streets very often, but one day I decided to go for a little drive. One reason that I don't usually drive the Porsche is because I have a hard time getting it into reverse. But since my new car is a five speed with the reverse gear in the same place, I thought "no problem"! Bad mistake...



We have the obligatory old refrigerator in our garage which sits in the corner in front of the Porsche about a foot or so ahead of the car (*I think I hear the snickers already*). Anyway, after a couple of tries to get the transmission into reverse I knew that I had it. Giving the car a little gas I turned to look over my shoulder behind me and let the clutch out. Hey-BUMP! Oh! Oh! I had put the transmission into fourth and the car went forward and hit the refrigerator door.

My heart stopped as I got out of the car and looked at the bumper and refrigerator...no damage that I could see, other than a small dent in the refrigerator door, the car looked all right though. Thinking to myself, "I won't say anything to David, he'll never notice the dent and car looked OK to me." So I didn't say anything.

The next day David was out in the garage doing something when I heard

(Continued on page 8)

# Watercooled Thoughts

by Paul Turner — Vice President



We have had a great year so far! Our event participation has been great and we still have many more great events remaining this year.

In April, we are having a Funkana in Palmdale. The details are not yet finalized, but rest assured they will be soon. Also in April, we are planning a trip to Las Vegas to attend the Las Vegas Region's Porsches Wild event; it is promising to be a great trip. I started a new column in the newsletter called Mechanics Mania. It is dedicated to dis-

cussing different mechanical areas of our cars, and if you have any suggestions or ideas for a

topic, please let me know and I will do the research and write a good column for you. I hope you found last month's article informative, I will try to keep them coming. Happy Driving! ●



Rich Bessette's 914 racer at the Porsches Wild Concours on Fremont Street. Photo by David Witteried...

## CINCO DE MAYO

### Zone 8 Concours & Autocross

**May 2 - 4, 2003**

Sponsored by: Southern Arizona Region, PCA, & Boudry Porsche

Designated Charity: Tucson Arthritis Support League (TASL)

**Headquarters and Accommodations:**  
 Ramada Inn Foothills Resort  
 Phone: 520-896-9595  
 Email: ramadafoothills@asl.com  
 Web: www.ramadafoothills.com  
 April 30th Deadline



6944 E. Tanque Verde Rd  
 Tucson, AZ 85715  
 Ask for Porsche Club Rate:  
 \$49.95/room or \$74.95/night  
 (includes Breakfast & Happy Hour)

**Boudry Warm-Up**  
 Friday, May 2, 2003  
 5:30 - 7:00 p.m.  
 Olive Tree Restaurant  
 7000 E. Tanque Verde  
 (In Santa Fe Plaza Patio)

**Concours D'Elegance**  
 Saturday, May 3, 2003  
 Car placement: 7:00 - 9:00 a.m.  
 Tucson Country Club  
 2950 N. Camino Principal  
 (In the Mesquite Grove)

**Awards Banquet**  
 Saturday, May 3, 2003  
 Social 6:30 p.m. (Patio)  
 Dinner 7:00 p.m. (Catalina Room)  
 Tucson Country Club  
 2950 N. Camino Principal

**Autocross - Pinal Air Park**  
 Sunday, May 4, 2003  
 Convoy leaves Ramada Inn  
 East Lot at 6:30 a.m.  
 Chair: J. P. Bruce (520) 546-1658  
 Email: jp.bruce@ieee.org  
 See Website for Zone 8 classes & Updates: [www.pca.org/saz](http://www.pca.org/saz)

**Event Chair:** Barb Crowley (520) 299-2288  
 Email: preacoupe@msn.com

**Registrar:** Audrey Cramer (520) 325-7203  
 2226 E. Water Street, Tucson, AZ 85719  
 Email: momcramer@msn.com

---

Name \_\_\_\_\_ Phone ( ) \_\_\_\_\_  
 (Please Print)

Address \_\_\_\_\_ Region \_\_\_\_\_

City \_\_\_\_\_ State \_\_\_\_\_ Zip \_\_\_\_\_ E-mail \_\_\_\_\_

Porsche Model \_\_\_\_\_ Year \_\_\_\_\_ Body Type \_\_\_\_\_

Color \_\_\_\_\_ License No. \_\_\_\_\_ Class \_\_\_\_\_  
 (Per Zone 8 rules)

Judged classes	\$40 per car	\$ _____	
Display class	\$25 per car	\$ _____	
Banquet Dinner	\$40 per person	\$ _____	(Reservation (check) by April 20th)
Autocross	\$40 per Driver	\$ _____	(\$45.00 after April 26th)
Purchased Shirts	\$15 X _____ =	\$ _____	(One shirt free with each entered car)
	<b>TOTAL</b>	<b>\$ _____</b>	

**Make Check Payable to PCA-SAR**      *Send to: Audrey Cramer, Registrar(address above)*

## Petersen Automotive Museum Tour

by David Witteried

On February 15<sup>th</sup> twelve members of California Inland Region, as well as a potential member with his son and a friend, met at the Marie Callender restaurant in Palmdale for a tour to the Petersen Automotive Museum in Los Angeles. We were met en route by four more members before we proceeded



1889 Beeston Quadricycle. Photo by David Witteried.

south into Los Angeles. This gave us nine Porsches and John Crankovich's truck (which we have taken to calling John's prototype Cayenne), a super turnout for our Region! Since there was a large antiwar protest planned that day we decided to drive down the 405, and then cut across Wilshire Boulevard to West Hollywood.

It was interesting to observe as we proceeded up Wilshire Boulevard how the automobiles around us became more and more expensive. I wouldn't be surprised if a few members didn't hurt their necks checking out some of the more exotic examples! We eventually arrived at the museum at the corner of Wilshire and Fairfax where we

parked as a group in the Petersen Museum parking garage. Since we came as a club those of us in our Porsches got free parking.

The Petersen Automotive Museum is a four-story building with 300,000 square feet of exhibits and 150 cars, trucks, and motorcycles on display. We were met on the first floor of the museum by a docent who led us on a very informative private tour of the automotive related dioramas that relate the history of the automobile in the L.A. area. The "Streetscape" tour begins in a downtown 1901 blacksmith shop where one of the first automobiles in Los Angeles was built, and concludes at a



Tour group listens to a Museum docent as he explains one of the exhibits. From left to right: Rich Paré, Paul Turner, Mary Ann Paré, Elaine Friend, Marvin Snodgrass, Donald Arthur; Foreground: Eleanor Charus and Joni Barnes. Photo by David Witteried.



Automobiles as art, a fish car. Photo by David Witteried.

(Continued on page 6)

## California Inland Region Gymkhana Precision Driving Event, 12 April



On the 12 of April we are having a Gymkhana Precision Driving event that will test your finer driving skills in a fun way!

There will be different obstacles to negotiate with some blind driving while being guided by your co-driver. Brush up on your driving and communication skills and come join us to see how good you really are!

The gymkhana was designed several years ago by Mike Forest. We dusted off his plans and actually located a place to hold the event. This will be a first for a region so make it a point to attend!

POC is Paul Turner (661) 823-9753.

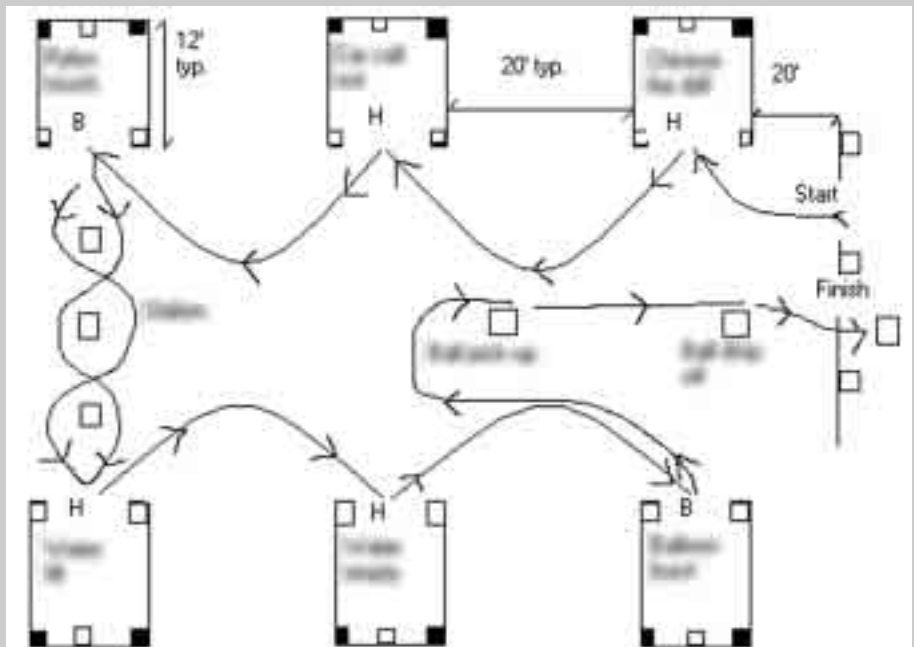

# From the Editor's Bench

by David Witteried — Winding Roads Editor



The Winding Roads newsletter has its first advertiser, Ted's Service Center! I was like to thank Ted for supporting our club and would encour-

age our members to patronize our advertisers. I'm still looking for somebody to go out and get me a few other advertisers. Advertising helps offset the cost of publishing the newsletter. We're currently operating under a deficit. However, one more business card size ad would put us at the breakeven point for the minimal mailing we're currently doing.



Contributing photographer John Crnkovich. Photo by David Witteried.

It currently costs the club \$60 per month to publish fifty newsletters. Forty-two of these newsletters are sent to members with the remainder sent to Zone and national representatives, leaving a few copies for Ted's Service Center waiting room to help advertise the club to nonmembers. Since I live in California City it is very difficult for



## Porsche Club of America, Grand Prix Region

### 22nd Annual Concours d'Elegance

Sunday, May 25, 2003

Sponsored by

## CIRCLE PORSCHE

1919 Lakewood Blvd. Long Beach, CA 90815  
562-597-3663

**Date:** Sunday, May 25, 2003  
**Cost:** Pre-Registration: \$40.00      After 5/15/03: \$45.00  
**Display Only:** Pre-Registration: \$15.00      After 5/15/03: \$20.00

**Location:** *Queen Mary Event Park* From the 910 Freeway take the 710 Freeway South to the Queen Mary. Exit at Harbor Plaza and then turn left. Cross S Harbor scenic Dr. (under the overpass). The Queen Mary Event Park is located (straight) ahead, between the Reef Restaurant and the Queen Mary's bow, a grassy park overlooking Shoreline Village and the L.B. Apartments.

**Time Schedules:** Car placement begins at 7:00 a.m.      Judging starts at 10:00 a.m.  
 Awards Ceremony at approximately 2:00 p.m.

CONCOURS DIVISION	STREET DIVISION	WASH & SHINE DIVISION
C-1 All 356 Closed	S-1 All 356 Closed	W/S-1 All 356's
C-2 All 356 Open	S-2 All 356 Open	W/S-2 All air-cooled Porsches except 356's
C-3 911-912 (65-73)	S-3 911-912 (65-73)	W/S-3 All water-cooled Porsches
C-4 911, 911 Turbo, 930, 912E (74-83)	S-4 911, 911 Turbo, 930, 912E (74-83)	W/S-4 Boxsters, 996's, Cayenne
C-5 911-Carrera, Turbo (84-89)	S-5 911-Carrera, Turbo (84-89)	
C-6 911-Carrera, Turbo 90-present including 89 C4 Carrera	S-6 911-Carrera, Turbo 90-present including 89 C4 Carrera	<b>Unrestored Division</b>
C-7 Boxster	S-7 Boxster	UR-1 All 356's
C-8 914, 914-6	S-8 914, 914-6	UR-3 911/912 (65-73)
C-9 All 924, 944, 928, & 968	S-9 All 924, 944, 928, & 968	UR-4 911/911 Turbo, 930, 912E (74-83)
C-10 Special Interest, Competition, Limited Production, Cayenne	S-10 Special Interest, Competition, Limited Production, Cayenne	UR-5 911/911 Turbo (air cooled 84 - Y10)
		UR-6 914, 914-6
		UR-9 All 924, 944, 928, 968
		UR-10 Special interest, competition, limited prod

----- Tear Here -----

Name: \_\_\_\_\_ Telephone: (\_\_\_\_) \_\_\_\_\_  
 Address: \_\_\_\_\_ PCA Region: \_\_\_\_\_ Zone: \_\_\_\_\_  
 \_\_\_\_\_ Class/Erncod: \_\_\_\_\_  
 (City) \_\_\_\_\_ (State) \_\_\_\_\_ (ZIP) \_\_\_\_\_  
 Porsche Model \_\_\_\_\_ Body Type \_\_\_\_\_ Year \_\_\_\_\_  
 E-mail: \_\_\_\_\_

Pre-register by 5/15/03: \$40.00. Judged: \$15.00. Display Only: (\$45.00 & \$20.00) respectively at event.  
 Please make check payable to: "PCA/GPX" and mail along with completed registration form to:  
**Marti Stewart, PCA/GPX Co-Chairperson**  
 2108 Rockefeller Lane, Unit B, Redondo Beach, CA 90278  
 310-937-0745      marti.stewart@verizon.net

Please Pre-Register for accurate Trophy count!

me to visit possible advertisers in Lancaster and Palmdale. Other possible advertisers are car dealers (Porsche owners do drive other vehicles), electronics specialty shops, racing shops etc.. I do not believe this would be a large investment in anybody's time. Please pitch in and help!

I encourage anybody who wants to contribute photographs for possible publication in the newsletter or use on the web site to please send me their snapshots. I have a scanner so prints are okay. If you want to send digital photographs send me your high-

resolution copies, preferably on CD as I only have dial-up connectivity to the Internet. Also, if you attend an event it can be fun to write an article for the newsletter regarding the trip. Fresh insights and perspectives are always welcome! Don't be surprised if I approach you at an event and ask you to write something about it. DON'T PANIC! It's not hard to do and my job as the newsletter editor is to make you look good.

See you on the road!

E-mail me with comments or ideas at: [witteried@ccis.com](mailto:witteried@ccis.com) ●



## Membership Report

by Greg Reed — Membership



Hello fellow CAI Region members. For the month of March, we had one member transfer in from another region.

Our chapter continues to grow and is now up to 42 members officially.

Please welcome our newest transfer: David & Johanne Vied from Santa Clarita. They drive a 1962 356. Can't wait to see that car David. Dare I say it, it is as old as I am. WELCOME!

Membership Anniversary in March, our very own President, Rich Pare' – 16 years. CONGRATULATIONS! ●

*Petersen Automotive Museum Tour (Continued from page 4)*

1960s garage. There are displays of an old "wooden" oval speedway race track, service stations, automobile dealerships, and the first (drive in) strip mall. One of the fun aspects of the dioramas is that you get to walk through them for an up-close experience.

After reviewing the first floor we proceeded to the second floor where there was

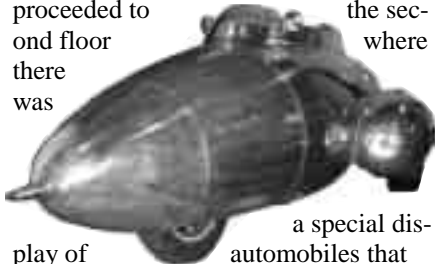

a special display of automobiles that were decorated by various artists.

There was a car decorated as a fish, a camera car which was covered with cameras; cars that were encrusted with figurines, brass, and in one case junk. I thought the "futuristic" rocket car was the most practical!

On the third floor of the museum was the May Family Discovery Center which is designed to teach children about science via the automobile. The "adults" in the group enjoyed playing with many of the exhibits, especially the drag race simulator. I hate to say it, but my wife beat me on the drag race game!

After enjoying all the exhibits the group reformed at the entrance of the museum before we fired up our Porsches for the short drive to Carney's

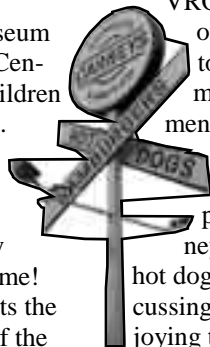

restaurant on Sunset Boulevard. As we were exiting the parking garage myself and Marvin Snodgrass began a contest of dueling exhaust systems. Vroom-VROOOM! Nothing like the sound of a 911 engine! The short drive to Carney's was made a little more exciting by the requirements of having to dice with the local L.A. drivers who love to drive while using their cell-phones. When we got to Carney's we enjoyed a quick meal of hot dogs and hamburgers while discussing the things we had seen and enjoying the non-stop parade of expensive automobiles on Sunset Boulevard. After the meal we posed for a group



# MEMORIAL WEEKEND James Dean Memorial Autocross for Charity

MINTER FIELD  
Shafter, California  
MAY 24, 2003 @ 7am

KOA CAMPING NEXT DOOR - KOA Bakersfield 661-399-3107,  
HOTEL ACCOMMODATIONS IN NEARBY BAKERSFIELD

Cost: \$50 in advance  
\$60 day of event

Greg Fuller (661) 831-8600, [gfullmer@bak.rr.com](mailto:gfullmer@bak.rr.com)  
Mike Bennett (661) 871-6586, [MJB993@aol.com](mailto:MJB993@aol.com)

Send Checks to Golden Empire Region  
1309 ASTOR AVE  
BAKERSFIELD, CA 93307

photo and the group broke up to make their separate ways home.

All-in-all this was a great event with a large turnout in which everybody had a great time! ●



Tour group outside of Carney's. From left to right: Donald Arthur, Marvin Snodgrass, Lynne Barnes, John Crnkovich, Eric Kimble, Paul Turner, Mark Charus, Ed Friend, Tim O'Hearn, Mike Forest, Elaine Friend, Joni Barnes, Brian O'Hearn, Janice Witteried, Eleanor Charus, Mary Ann Paré. Photo by David Witteried.



## Region Secretary Report

by Mark Charus — Secretary



Executive Board Meeting, 19 February 2003 at Zuma's Restaurant.

Old Business:

- Events calendar discussed for the

coming year.

- Also a month to month calendar discussed featuring club member's cars as a cover page for each month.

Treasurer Report

- Funds received from the last two events, The Dam Tour and Peterson Museum
  - Holiday Party Fund started and discussion of funds for use as a charitable donation for a family in need.
- Membership Report
- 1 new member 2 transfers in.
  - 41 Cal- Inland members as of this date.
  - Membership drive is ongoing, always looking for new members.
  - The newsletter is being left at Ted's German Auto Repair in hopes of attracting members Current Cal-Inland members should carry at least one Pano and PCA application form.

Newsletter Report

- The new newsletter editor is David, and the February issue was Outstanding and enjoyed by all the members.
- The next issue is in progress.

Webmaster Report

- The website has a new format, the site appears to be easier to navigate, and is currently being updated.

Events Report

- The last event was The Peterson Museum and members made a strong showing, nine Porsches and one prototype pickup made the tour to Los Angeles.

Next tour event is the Scavenger Hunt, POC is Paul Turner.

National news was reported.

New business was discussed.

Next Board meeting is 19 March 2003 at Zuma's.

Meeting adjourned at 7:20 PM. ●

## How Much per Gallon! by Unknown—The Internet

You think gas is expensive? Stop and consider:

- Diet Snapple 16 oz \$1.29...\$10.32 per gallon
- Lipton Ice Tea 16 oz \$1.19...\$9.52 per gallon
- Gatorade 20 oz \$1.59...\$10.17 per gallon
- Ocean Spray 16 oz \$1.25...\$10.00 per gallon
- Brake Fluid 12 oz \$3.15...\$33.60 per gallon
- Vick's Nyquil 6 oz \$8.35...\$178.13 per gallon
- Pepto Bismol 4 oz \$3.85...\$123.20 per gallon
- Whiteout 7 oz \$1.39...\$25.42 per gallon

And this is the REAL KICKER...

Evian water 9 oz \$1.49...\$21.19 per gallon?! \$21.19 for WATER - and the buyers don't even know the source.

So, the next time you're at the pump, be glad your car doesn't run on water, Scope, or Whiteout, or God forbid Pepto Bismol or Nyquil.

Just a little humor to help ease the pain of your next trip to the pump! ●

### PORSCHE WILD III

LAS VEGAS / APRIL 2003

Casino Boss: Roger Greene  
Pit Bosses: Nita Burrows, Nina Cooper  
Dealers: The Entire LV Region

To Place Your Bets Send Application to Nita Burrows for information email nb827@aol.com

Las Vegas Region, Porsche Club of America, Zone 8 Rules Apply

APPLICATION	1	2	Amount
<b>April 18, Concour</b> Fremont Street Experience Car Placement Begins at 7AM Judging Begins 9AM Entry before 4PM \$40, after \$50	_____	_____	_____
<b>April 20, Autocross</b> Las Vegas Motor Speedway Reg. 7:30AM Drivers Mtg. 8:30AM 1st Car Out 9AM Entry before 4PM \$40, after \$50	_____	_____	_____
<b>Porsches Wild Event T-Shirt</b> \$15.00 Indicate Size	_____	_____	_____
<b>Total</b>			_____

Send Application and Check to LVRPCA  
c/o Nita Burrows 5565 N. Campbell Rd.  
Las Vegas, NV 89149

Driver/Entrant \_\_\_\_\_ PCA Region \_\_\_\_\_  
Co-Driver/Entrant \_\_\_\_\_ PCA Region \_\_\_\_\_  
Address \_\_\_\_\_  
\_\_\_\_\_ City \_\_\_\_\_  
State \_\_\_\_\_ Zip \_\_\_\_\_  
Phone \_\_\_\_\_ email \_\_\_\_\_  
Car Model \_\_\_\_\_ Body Type \_\_\_\_\_

Concour Level: Full \_\_\_\_\_ Street \_\_\_\_\_ Wash n Shine \_\_\_\_\_ Exhibit only \$10 \_\_\_\_\_

Rooms have been blocked out at the Golden Nugget \$69 for 4/18&19.  
Call the hotel at 702 385 7111 before March 15th for reservations and mention the Porsche Club.

From the Zone Rep (Continued from page 2) activities competitive programs will be unable to provide. This is a great group tour for region members.

ZONE 8 NEWS

I am pleased to report that Zone 8 has enjoyed another very successful year of growth, a record number of region and zone events, expanded resources and services to members, and national awards and recognition.

Zone membership has grown to 6,025, and your efforts to make your regions and Zone 8 so successful are greatly appreciated. All members should be able to find an appealing activity, as there will be ample Zone events (9 AX's, 12 Concours, 6 Rallies, 3 Time Trials, 2 Club Races, and the 5th annual Concours Judging School), in addition to many and varied region events.

I am particularly pleased to see the increase of cross-regional activities and support for one another's activities. It has brought a new level of cooperation and sharing of talents and skills. We are a community of diverse interests and needs, but your ability to come together and meld your talents has made Zone 8 truly outstanding.

I had the pleasure of attending outstanding end-of-year events and holiday parties. It was especially gratifying to see the level of participation by small regions; one small region had more than two-thirds of its members in attendance (*that would be us...Ed.*). I am so proud of the efforts of all region presidents to host activities that generate participation, editors who work tirelessly to provide informative and entertaining newsletters, web masters who provide the latest information on exceptionally creative and attractive sites, zone staff for their dedication that exceeds what any volunteer should provide, and members whose energy, enthusiasm, and creativity, continually amazes me.

I would like to express my gratitude to Richard Price, Concours Chair, and Bill Enke, Time Trial Chair, for their outstanding contribution to the Zone staff and the members of the Zone over the years. Their presence will be greatly missed. Julio Picchio, Arizona Region, will be replacing Richard as Concours Chair. I know we



**Newport Auto Center Presents**  
The 33<sup>rd</sup> Annual  
*White Gloves Concours*

In conjunction with the 18<sup>th</sup> Annual  
**Huntington Beach Concours d'Elegance**  
**Sunday June 1, 2003**  
Huntington Beach Central Park  
On Talbot Ave between Golden West & Beach Blvd.



The Concours benefits the Huntington Beach Library's Children's Resource Center. This facility for Orange County children is a state-of-the-art learning center ranked No. 2 nationally.



<p><b>Schedule of Events</b> 8:00 A.M. - 8:00 A.M. Registration &amp; Car Placement 8:00 A.M. - 9:00 A.M. First Presentation 8:15 A.M. - Zone 8 Judging Meeting 8:30 A.M. - Entry Judging Period (Judgement) 1:30 P.M. - Awards Assembly</p>	<p><b>Concours Division</b> C-1 All Closed 350's C-2 All Open 350's C-3 811 - 912 (1965-1973) C-4 811 - 911 Turbo, 902E &amp; 908 (1974-1984) C-5 811 Carrera &amp; Turbo (1984-1989) C-6 911 Carrera &amp; Turbo (1990-Present inc. 968 C4) C-7 Boxster C-8 914-4 &amp; 914-S C-9 All models 924, 944, 928 &amp; 968 C-10 Special Interest, Custom Competition &amp; Limited Production, Cayenne</p>	<p><b>Street Division</b> S-1 All Closed 350's S-2 All Open 350's S-3 811 - 912 (1965-1973) S-4 811 - 911 Turbo, 902E &amp; 908 (1974-1984) S-5 811 Carrera &amp; Turbo (1984-1989) S-6 911 Carrera &amp; Turbo (1990-Present inc. 968 C4) S-7 Boxster S-8 914-4 &amp; 914-S S-9 All models 924, 944, 928 &amp; 968 S-10 Special Interest, Custom Competition &amp; Limited Production, Cayenne</p>
--	---	---

<p><b>Unrestored Division</b> UR-1 All 350's UR-2 912 &amp; 911 (1965-1973) UR-3 811, 911 Turbo, 912E &amp; 910 (1974-84) UR-4 911 &amp; 911 Turbo (86-93) UR-5 914-4 &amp; 914-S UR-9 All models 924, 944, 928 &amp; 968 UR-10 Special Int., Custom Comp., Ltd Prod</p>	<p><b>Wash &amp; Shine</b> WR-1 All 350's WR-2 All Cocked Purses WR-3 All Water Cooled Purses WR-4 All Boxsters, 998 &amp; Cayenne</p>	<p><b>Display Only - Not Judged</b> D Display</p>
--	--	---

---

Name: \_\_\_\_\_ Phone: \_\_\_\_\_  
Address: \_\_\_\_\_  
City: \_\_\_\_\_ State: \_\_\_\_\_ Zip: \_\_\_\_\_  
E-mail: \_\_\_\_\_ PCA Region: \_\_\_\_\_  
Model: \_\_\_\_\_ Year: \_\_\_\_\_ Body Type: \_\_\_\_\_ License #: \_\_\_\_\_  
Class Entered: \_\_\_\_\_ Registration Fee: \_\_\_\_\_

Your entry fee allows an opportunity for two awards if you request to be judged by Zone 8 and Huntington Beach officials. — Check  to confer entry for both.

Huntington Beach Concours d'Elegance is a charitable organization.  
Tax deductible amount for each entry is \$25.00.

Entry Fee includes 2 adult entrance passes, goodwill bag, and commemorative ribbon.

**Advanced Registration Fees**  
(Received Before May 16)

Display Class - not judged (Includes 2 entrance passes) \$25.00  
Judged Classes (Includes 2 entrance passes) \$45.00  
Registration after May 16: add \$10.00

Please make check payable to:  
**PCA-OCR** and mail to:  
David Casarola  
Concours Registration  
4485 E. Emburywood Lane  
Anaheim Hills, CA 92807

Spectator admission: \$10.00  
Children under 12 & accompanied are free  
General Information: (714) 375-9023  
[www.tbconcours.org](http://www.tbconcours.org)

all appreciate the work of Bill and Richard, and wish Julio the best in his appointment.

I am enthused about future successes, as regions continue to expand their programs and efforts to meet the needs of their members, and work to expand membership through creative and innovative activities. Tom Bobbitt said PCA should be about fun, friends, and support for one another that sounds like Zone 8 to me. I eagerly look forward to attending events this year and having the opportunity to visit with you, as together, we work to have another great year in Zone 8. ●



Things that go Bump (Continued from page 3)

him call. Not thinking anything of it I went out to see what he wanted. That's when I learned that men know everything about their cars. He was getting something from his work bench when he noticed a black mark, then the dent on the refrigerator door. It didn't take him long to figure out what had happened. He didn't say much, but if looks could kill I wouldn't have been able to write this story. I did get another lecture on how to get the car into reverse again...maybe death would have been better. ●



## Zone 8 Staff

<http://www.pca.org/zone8>

### Zone Representative

Mike Mansolino  
mmansolino@earthlink.net  
714.771.6464

### Reporter/Web

Bev Giffin-Frohm  
bevfrohm@yahoo.com  
949.387.2443

### Concours

Richard Price  
rtp356@aol.com  
949.831.2381

### Rally

Revere Jones  
revrally@aol.com  
626.791.9433

### Time Trial

Paul Young  
pdyoung@cox.net  
619.449.1768

### Autocross

Michael Dolphin  
carrera3@msn.com  
626.798.2312

### Chief Driving Instructor

Vince Knauf  
vvvince@aol.com  
619.287.4334

### Rules Committee

John Burrows  
jcb986@aol.com  
702.394.3886

**Help wanted!** The Winding Roads staff requires helps selling advertising to local merchants! If you're interested in this position please contact David Witteried, Winding Roads Editor, 661.760.1413 or witteried@ccis.com.

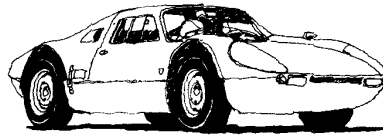

## Commercial Ads

Full-page \$75.00/month  
1/2 page \$35.00/month  
1/4 page \$15.00/month  
Business card \$5.00/month

Ad includes a banner ad & link from our web site at [www.pca.org/cai](http://www.pca.org/cai).

Deadline for submitting new ads for making changes to existing ads is the first of the month preceding the month of publication.

We reserve the right to refuse to print any ad deemed inappropriate.

Send ads to:  
David Witteried  
9900 Susan Avenue  
California City, CA 93505  
witteried@Hotmail.com

## Classified Ads

No charge to PCA members.

Ads will be left for a reasonable amount of time. However, please let us know when the item has been sold.

Non-member ads:  
\$25.00 for each 25 words (per issue).  
No extra charge to include photo.

Ads are automatically included on our region web site.

We reserve the right to edit or refuse to print any ad.

Send ads to (e-mail preferred):  
David Witteried  
9900 Susan Avenue  
California City, CA 93505  
witteried@Hotmail.com



**ADVERTISING  
SPACE IS AVAILABLE!**

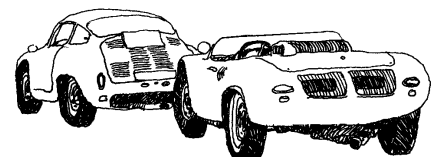



**WINDING ROADS**  
California Inland Region  
David Witteried/Editor  
9900 Susan Avenue  
California City, CA 93505



## **Our Next Event...**

**April 12**

## **Gymkhana/Precision Driving Contest**

**POC – Paul Turner  
(661) 823-9753**

*(See page 4 for details)*

